

DOG SERIES 3.3V SUPER FLAT / 55x27mm

INCL. CONTROLLER ST7036 FOR 4-/8-BIT, SPI (4-WIRE)

available for 1 pc. off!
even with LED: 5.8mm flat

EA DOGM163B-A
blue

EA LED55x31-W
white

EA DOGM081S-A
+ EA LED55x31-W

EA DOGM081W-A
+ EA LED55x31-B

EA DOGM162E-A
+ EA LED55x31-G

EA DOGM162W-A
+ EA LED55x31-A

EA DOGM163W-A
+ EA LED55x31-W

TECHNICAL DATA

- * HIGH-CONTRAST LCD SUPERTWIST DISPLAY
- * OPTIONAL LED BACKLIGHT UNITS IN DIFFERENT COLORS
- * 1x8, 2x16 AND 3x16 WITH 12.0 mm / 5.6 mm AND 3.6 mm CHARACTER HEIGHT
- * ST 7036 CONTROLLER FOR 4-BIT, 8-BIT AND SPI (4-WIRE) INTERFACE
- * POWER SUPPLY +3.3V OR +5V SINGLE SUPPLY (typically 250µA)
- * NO ADDITIONAL VOLTAGES REQUIRED
- * OPERATING TEMPERATURE RANGE -20 THROUGH +70°C
- * LED BACKLIGHT 3 through 80mA @ 3.3V or 2 through 40mA @ 5V
- * NO MOUNTING REQUIRED, SIMPLY SOLDER INTO PCB

ORDERING CODE

LCD MODULE 1x8 - 11.97mm
LCD MODULE 2x16 - 5.57mm
LCD MODULE 3x16 - 3.65mm

EA DOGM081x-A
EA DOGM162x-A
EA DOGM163x-A

x: B = blue background

E = yellow/green background

L = yellow/green background (cannot be backlit)

S = black background

W = white background

LED BACKLIGHT, WHITE
LED BACKLIGHT, YELLOW/GREEN
LED BACKLIGHT, BLUE
LED BACKLIGHT, RED
LED BACKLIGHT, AMBER

EA LED55X31-W
EA LED55X31-G
EA LED55X31-B
EA LED55X31-R
EA LED55X31-A

SOCKET CONNECTOR 4.8 mm HIGH (1x20-PIN, 2.54mm PITCH)

EA FL-20P

**ELECTRONIC
ASSEMBLY** GMBH
making things easy

LOCHHAMER SCHLAG 17 · D - 82 166 GRAEFELFING
Phone +49-89-8541991 · FAX +49-89-8541721 · <http://www.lcd-module.de>

EA DOG SERIES

With its EA DOG series, ELECTRONIC ASSEMBLY presents the world's first display series which will run on 3.3 V systems without auxiliary power. They can, of course be used on traditional 5 V systems. Unlike normal LCD modules, you order the display and the corresponding backlight separately. This gives you a wealth of possible combinations.

Designed for compact hand-held devices, this modern LCD range provides a number of real benefits with or without backlight:

- * extremely compact at 55 x 31 mm at the standard font size of 5.57 mm (2 x 16)
- * ultra-flat at 2.0 mm without backlight or 5.8 mm including LED backlight
- * 4-bit, 8-bit and SPI interface (4-wire)
- * typical power consumption of only 250µA in full operation (LED white backlight as of 3mA)
- * easy installation by simply soldering into the board
- * A whole range of design variants (63) can be supplied as of single units

SETTING THE CONTRAST

The contrast on all displays of the EA DOG series can be set with a command. This is done using bits C0 through C5 in the commands "Contrast Set" and "Power/Icon Control/Contrast Set". Generally, the contrast is set once and kept constant across the entire operating temperature range (-20 through +70°C) thanks to the integrated temperature compensation function.

Even when run at 3.3 V, the displays do not require any additional negative voltage!

LED BACKLIGHTS

5 different variants are available for individual backlighting: white, yellow/green, blue, red and amber.

In each case, 2 separate LED paths are available, which can be switched in parallel or in series to ideally match the system voltage. This means that all the backlights can be run either at 5 V or at 3.3 V.

Operation of the backlight requires an external series resistor for current limiting. This can be calculated from $R=U/I$; you will find the values in the table. To improve life time it is recommended to use a current source only.

The operating life of the yellow/green, red and amber backlights is 100,000 hours and that of the white and blue backlights much shorter.

Important: Never operate the backlight directly on a 5 V/3.3 V supply, as this can immediately destroy the LEDs!

INSTALLATION

First, the display and the corresponding backlight are clipped together. The complete unit is then inserted into a PCB and soldered. Note that the 4 pins for the backlight must also be soldered from the top.

Important: There are two protective films on the display and one on each backlight. These should be removed during or after production.

| yellow/green EA LED55x31-G | Forward voltage | Current max. | Limiting resistor | |
|-------------------------------|--------------------|-----------------|-------------------|---------|
| | | | @ 3,3 V | @ 5 V |
| Connected in parallel | 2,2 V | 80 mA | 14 ohm | 35 ohm |
| Connected in series | 4,4 V | 40 mA | - | 7,5 ohm |

| white EA LED55x31-W | Forward voltage | Current max. | Limiting resistor | |
|------------------------|--------------------|-----------------|-------------------|--------|
| | | | @ 3,3 V | @ 5 V |
| Connected in parallel | 3,2 V | 60 mA | 1,6 ohm | 30 ohm |
| Connected in series | 6,4 V | 30 mA | - | - |

| blue EA LED55x31-B | Forward voltage | Current max. | Limiting resistor | |
|-----------------------|--------------------|-----------------|-------------------|--------|
| | | | @ 3,3 V | @ 5 V |
| Connected in parallel | 3,2 V | 60 mA | 1,6 ohm | 30 ohm |
| Connected in series | 6,4 V | 30 mA | - | - |





| amber EA LED55x31-A | Forward voltage | Current max. | Limiting resistor | |
|------------------------|--------------------|-----------------|-------------------|--------|
| | | | @ 3,3 V | @ 5 V |
| Connected in parallel | 2,4 V | 80 mA | 11 ohm | 32 ohm |
| Connected in series | 4,8 V | 40 mA | - | 5 ohm |

| red EA LED55x31-R | Forward voltage | Current max. | Limiting resistor | |
|-----------------------|--------------------|-----------------|-------------------|--------|
| | | | @ 3,3 V | @ 5 V |
| Connected in parallel | 2,1 V | 80 mA | 15 ohm | 36 ohm |
| Connected in series | 4,2 V | 40 mA | - | 20 ohm |

ELECTRONIC ASSEMBLY

5 DIFFERENT TECHNOLOGIES

As a standard we provide 5 different technologies as STN and FSTN:

| display type | technology | optional backlight | readability | display color non backlighted | display color with backlighted | recommended backlight color |
|---|------------------------------------|--------------------------------------|-----------------------------------|-------------------------------|-------------------------------------|-----------------------------|
|  | FSTN pos. transfective | it's fine with and without backlight | readable even without backlight | black on white | black on backlight color | white, blue |
|  | STN pos. yellow/green transmissive | backlight unit required | readable even without backlight | dark green on yellow/green | black on yellow/green or amber | yellow/green, amber |
|  | STN neg. blue transmissive | usage only with backlight | --- | --- | backlight color on blue background | white, yellow/green |
|  | FSTN neg. transmissive | usage only with backlight | --- | --- | backlight color on black background | white |
|  | STN pos. yellow/green reflective | no backlight possible | finest readable without backlight | dark green on yellow/green | --- | --- |

3 DIFFERENT DISPLAYS

These displays are available for mentioned technologies:



5 DIFFERENT BACKLIGHTS

5 different backlight colors are available to match equipments design as much as possible. The most effective and brightest one is the white one EA LED55x31-W.



EA LED55x31-W
White

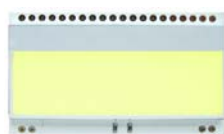

EA LED55x31-G
Yellow/Green



EA LED55x31-B
Blue



EA LED55x31-R
Red

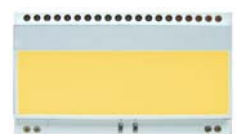

EA LED55x31-A
Amber

When you can see black and white pictures only here on this page then you're able to download a coloured version from our website <http://www.lcd-module.de/eng/pdf/doma/dogme.pdf>

APPLICATION EXAMPLES

Different wiring must be used depending on the interface and the power supply. 2 additional capacitors are required for 3.3 V operation.

Note that the COG technology means that the current capacity of the outputs is limited. Therefore, a large load on the bus may cause signal loops and unclean levels. If in doubt, additional pull-down resistors (8051) are required or additional waits/NOPs must be incorporated.

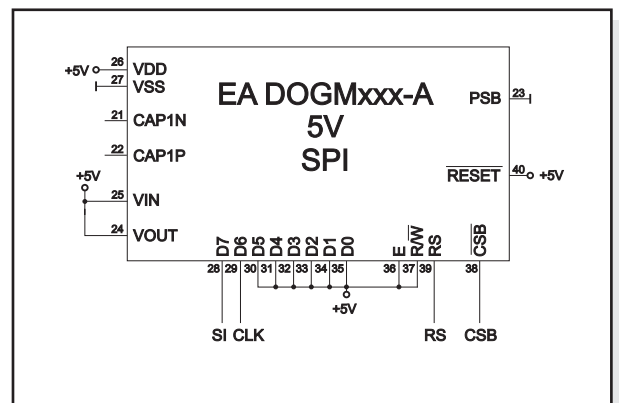
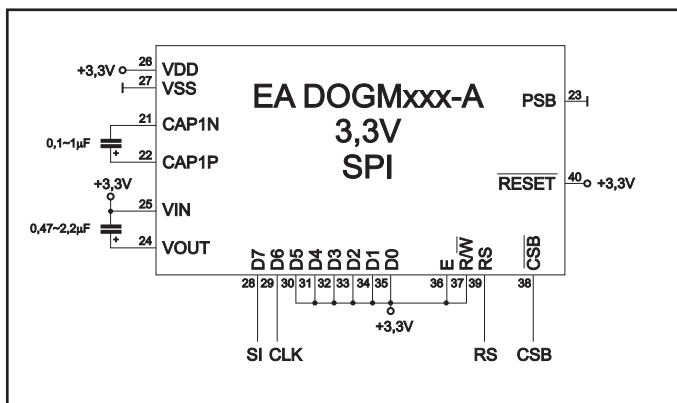
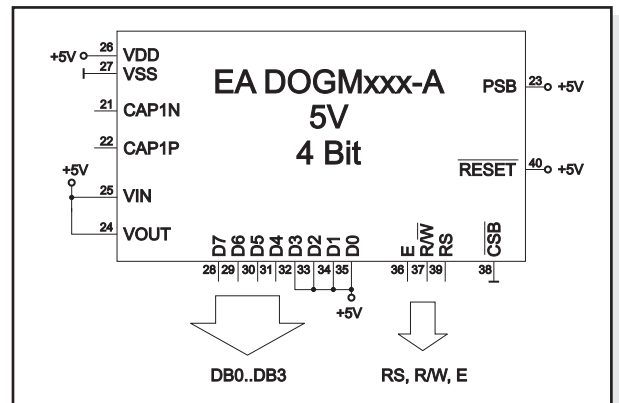
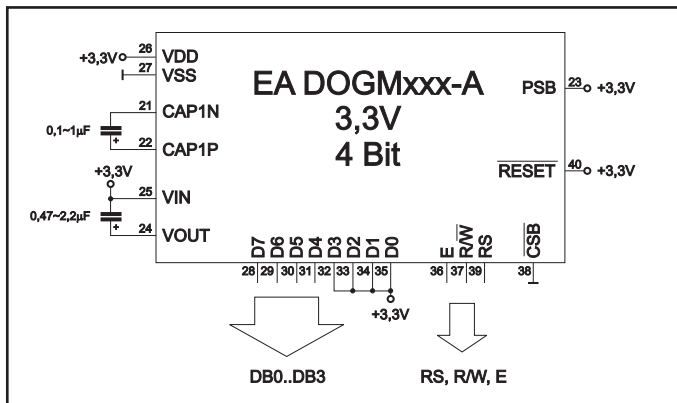
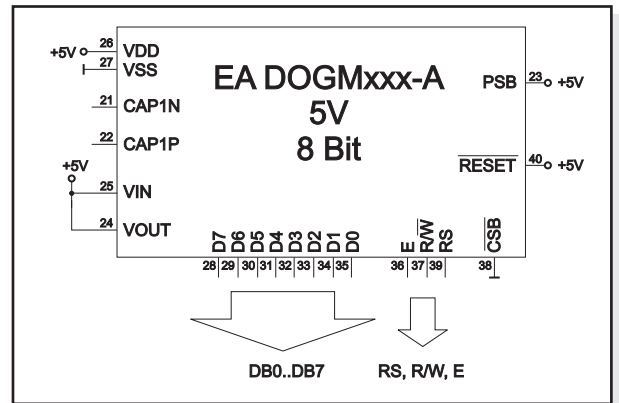
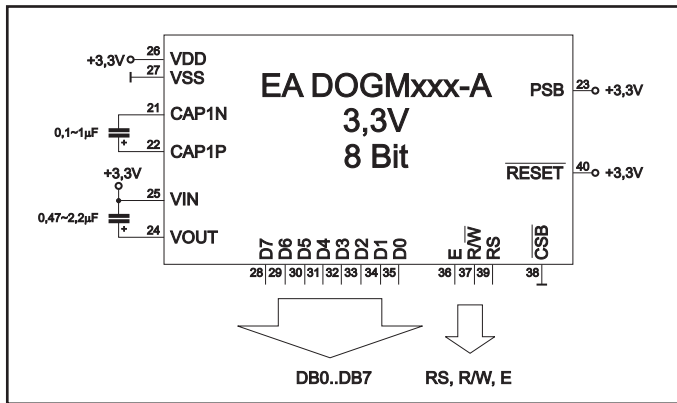

ELECTRONIC ASSEMBLY

CHARACTER SET

The below show character set is already built-in. In addition to that you are able to define 8 characters by your own.

| b7-b4 b3-b0 | 0000 | 0001 | 0010 | 0011 | 0100 | 0101 | 0110 | 0111 | 1000 | 1001 | 1010 | 1011 | 1100 | 1101 | 1110 | 1111 |
|----------------|------|------|------|------|------|------|------|------|------|------|------|------|------|------|------|------|
| 0000 | | | | | | | | | | | | | | | | |
| 0001 | | | | | | | | | | | | | | | | |
| 0010 | | | | | | | | | | | | | | | | |
| 0011 | | | | | | | | | | | | | | | | |
| 0100 | | | | | | | | | | | | | | | | |
| 0101 | | | | | | | | | | | | | | | | |
| 0110 | | | | | | | | | | | | | | | | |
| 0111 | | | | | | | | | | | | | | | | |
| 1000 | | | | | | | | | | | | | | | | |
| 1001 | | | | | | | | | | | | | | | | |
| 1010 | | | | | | | | | | | | | | | | |
| 1011 | | | | | | | | | | | | | | | | |
| 1100 | | | | | | | | | | | | | | | | |
| 1101 | | | | | | | | | | | | | | | | |
| 1110 | | | | | | | | | | | | | | | | |
| 1111 | | | | | | | | | | | | | | | | |

A detailed description for integrated controller ST7036 you can find under <http://www.lcd-module.de/eng/pdf/zubehoer/st7036.pdf>

TABLE OF COMMAND

| Instruction | Instruction Code | | | | | | | | | | Description | Instruction Execution Time | | | |
|----------------------------|------------------|-----|-----|-----|-----|-----|-----|-----|-----|-----|---|--|------------|------------|---------|
| | RS | R/W | DB7 | DB6 | DB5 | DB4 | DB3 | DB2 | DB1 | DB0 | | OSC=380kHz | OSC=540kHz | OSC=700kHz | |
| Clear Display | 0 | 0 | 0 | 0 | 0 | 0 | 0 | 0 | 0 | 1 | Write "20H" to DDRAM, and set DDRAM address to "00H" from AC | 1.08 ms | 0.76 ms | 0.59 ms | |
| Return Home | 0 | 0 | 0 | 0 | 0 | 0 | 0 | 0 | 0 | 1 | x | Set DDRAM address to "00H" from AC and return cursor to its original position if shifted. The contents of DDRAM are not changed. | 1.08 ms | 0.76 ms | 0.59 ms |
| Entry Mode Set | 0 | 0 | 0 | 0 | 0 | 0 | 0 | 1 | I/D | S | Sets cursor move direction and specifies display shift. These operations are performed during data write and read. | 26.3 μs | 18.5 μs | 14.3 μs | |
| Display ON/OFF | 0 | 0 | 0 | 0 | 0 | 0 | 1 | D | C | B | D=1:entire display on C=1:cursor on B=1:cursor position on | 26.3 μs | 18.5 μs | 14.3 μs | |
| Function Set | 0 | 0 | 0 | 0 | 1 | DL | N | DH | IS2 | IS1 | DL: interface data is 8/4 bits N: number of line is 2/1 DH: double height font IS[2:1]: instruction table select | 26.3 μs | 18.5 μs | 14.3 μs | |
| Set DDRAM Address | 0 | 0 | 1 | AC6 | AC5 | AC4 | AC3 | AC2 | AC1 | AC0 | Set DDRAM address in address counter | 26.3 μs | 18.5 μs | 14.3 μs | |
| Read Busy Flag and Address | 0 | 1 | BF | AC6 | AC5 | AC4 | AC3 | AC2 | AC1 | AC0 | Whether during internal operation or not can be known by reading BF. The contents of address counter can also be read. | 0 | 0 | 0 | |
| Write Data to RAM | 1 | 0 | D7 | D6 | D5 | D4 | D3 | D2 | D1 | D0 | Write data into internal RAM (DDRAM/CGRAM/ICONRAM) | 26.3 μs | 18.5 μs | 14.3 μs | |
| Read Data from RAM | 1 | 1 | D7 | D6 | D5 | D4 | D3 | D2 | D1 | D0 | Read data from internal RAM (DDRAM/CGRAM/ICONRAM) | 26.3 μs | 18.5 μs | 14.3 μs | |

Instruction table 0(IS[2:1]=[0,0])

| | | | | | | | | | | | | | | |
|-------------------------|---|---|---|---|-----|-----|-----|-----|-----|-----|---|---------|---------|---------|
| Cursor or Display Shift | 0 | 0 | 0 | 0 | 0 | 1 | S/C | R/L | X | X | S/C and R/L: Set cursor moving and display shift control bit, and the direction, without changing DDRAM data. | 26.3 μs | 18.5 μs | 14.3 μs |
| Set CGRAM | 0 | 0 | 0 | 1 | AC5 | AC4 | AC3 | AC2 | AC1 | AC0 | Set CGRAM address in address counter | 26.3 μs | 18.5 μs | 14.3 μs |

Instruction table 1(IS[2:1]=[0,1])

| | | | | | | | | | | | | | | |
|----------------------------------|---|---|---|---|---|---|-----|------|------|------|---|---------|---------|---------|
| Bias Set | 0 | 0 | 0 | 0 | 0 | 1 | BS | 1 | 0 | FX | BS=1:1/4 bias BS=0:1/5 bias FX: fixed on high in 3-line application and fixed on low in other applications. | 26.3 μs | 18.5 μs | 14.3 μs |
| Set ICON Address | 0 | 0 | 0 | 1 | 0 | 0 | AC3 | AC2 | AC1 | AC0 | Set ICON address in address counter. | 26.3 μs | 18.5 μs | 14.3 μs |
| Power/ICON Control/ Contrast Set | 0 | 0 | 0 | 1 | 0 | 1 | Ion | Bon | C5 | C4 | Ion: ICON display on/off Bon: set booster circuit on/off C5,C4: Contrast set for internal follower mode. | 26.3 μs | 18.5 μs | 14.3 μs |
| Follower Control | 0 | 0 | 0 | 1 | 1 | 0 | Fon | Rab2 | Rab1 | Rab0 | Fon: set follower circuit on/off Rab2~0: select follower amplified ratio. | 26.3 μs | 18.5 μs | 14.3 μs |
| Contrast Set | 0 | 0 | 0 | 1 | 1 | 1 | C3 | C2 | C1 | C0 | Contrast set for internal follower mode. | 26.3 μs | 18.5 μs | 14.3 μs |

Instruction table 2(IS[2:1]=[1,0])

| | | | | | | | | | | | | | | |
|-------------------------------|---|---|---|---|---|---|----|---|---|---|-----------------------------------|---------|---------|---------|
| Double Height Position Select | 0 | 0 | 0 | 0 | 0 | 1 | UD | X | X | X | UD: Double height position select | 26.3 μs | 18.5 μs | 14.3 μs |
| Reserved | 0 | 0 | 0 | 1 | X | X | X | X | X | X | Do not use (reserved for test) | 26.3 μs | 18.5 μs | 14.3 μs |

A detailed description for integrated controller ST7036 you can find under <http://www.lcd-module.de/eng/pdf/zubehoer/st7036.pdf>

ELECTRONIC ASSEMBLY

EXAMPLES FOR INITIALISATION

EA DOGM081

| Example of initialisation: 8 bit / 3.3V | | | | | | | | | | | |
|---|----|-----|-----|-----|-----|-----|-----|-----|-----|-----|---|
| EA DOGM081 | | | | | | | | | | | |
| Command | RS | R/W | DB7 | DB6 | DB5 | DB4 | DB3 | DB2 | DB1 | DB0 | Hex Note |
| Function Set | 0 | 0 | 0 | 0 | 1 | 1 | 0 | 0 | 0 | 1 | \$31 8 bit data length, 1 line, instruction table 1 |
| Bias Set | 0 | 0 | 0 | 0 | 0 | 1 | 0 | 1 | 0 | 0 | \$14 BS: 1/5, 1 line LCD |
| Power Control | 0 | 0 | 0 | 1 | 0 | 1 | 0 | 1 | 0 | 1 | \$55 booster on, contrast C5, set C4 |
| Follower Control | 0 | 0 | 0 | 1 | 1 | 0 | 1 | 1 | 0 | 1 | \$6D set voltage follower and gain |
| Contrast Set | 0 | 0 | 0 | 1 | 1 | 1 | 1 | 1 | 0 | 0 | \$7C set contrast C3, C2, C1 |
| Display ON/OFF | 0 | 0 | 0 | 0 | 0 | 0 | 1 | 1 | 1 | 1 | \$0F display on, cursor on, cursor blink |
| Clear Display | 0 | 0 | 0 | 0 | 0 | 0 | 0 | 0 | 0 | 1 | \$01 delete display, cursor at home |
| Entry Mode Set | 0 | 0 | 0 | 0 | 0 | 0 | 0 | 1 | 1 | 0 | \$06 cursor auto-increment |

Initialisation for 3.3V

| Example of initialisation: 8 bit / 5V | | | | | | | | | | | |
|---------------------------------------|----|-----|-----|-----|-----|-----|-----|-----|-----|-----|---|
| EA DOGM081 | | | | | | | | | | | |
| Command | RS | R/W | DB7 | DB6 | DB5 | DB4 | DB3 | DB2 | DB1 | DB0 | Hex Note |
| Function Set | 0 | 0 | 0 | 0 | 1 | 1 | 0 | 0 | 0 | 1 | \$31 8 bit data length, 1 line, instruction table 1 |
| Bias Set | 0 | 0 | 0 | 0 | 0 | 1 | 1 | 1 | 0 | 0 | \$1C BS: 1/4, 1 line LCD |
| Power Control | 0 | 0 | 0 | 1 | 0 | 1 | 0 | 0 | 0 | 1 | \$51 booster off, contrast C5, set C4 |
| Follower Control | 0 | 0 | 0 | 1 | 1 | 0 | 1 | 0 | 1 | 0 | \$6A set voltage follower and gain |
| Contrast Set | 0 | 0 | 0 | 1 | 1 | 1 | 0 | 1 | 0 | 0 | \$74 set contrast C3, C2, C1 |
| Display ON/OFF | 0 | 0 | 0 | 0 | 0 | 0 | 1 | 1 | 1 | 1 | \$0F display on, cursor on, cursor blink |
| Clear Display | 0 | 0 | 0 | 0 | 0 | 0 | 0 | 0 | 0 | 1 | \$01 delete display, cursor at home |
| Entry Mode Set | 0 | 0 | 0 | 0 | 0 | 0 | 0 | 1 | 1 | 0 | \$06 cursor auto-increment |

Initialisation for 5V

EA DOGM162

| Example of initialisation: 8 Bit / 3.3V | | | | | | | | | | | |
|---|----|-----|-----|-----|-----|-----|-----|-----|-----|-----|--|
| EA DOGM162 | | | | | | | | | | | |
| Command | RS | R/W | DB7 | DB6 | DB5 | DB4 | DB3 | DB2 | DB1 | DB0 | Hex Note |
| Function Set | 0 | 0 | 0 | 0 | 1 | 1 | 1 | 0 | 0 | 1 | \$39 8 bit data length, 2 lines, instruction table 1 |
| Bias Set | 0 | 0 | 0 | 0 | 0 | 1 | 0 | 1 | 0 | 0 | \$14 BS: 1/5, 2 line LCD |
| Power Control | 0 | 0 | 0 | 1 | 0 | 1 | 0 | 1 | 0 | 1 | \$55 booster on, contrast C5, set C4 |
| Follower Control | 0 | 0 | 0 | 1 | 1 | 0 | 1 | 1 | 0 | 1 | \$6D set voltage follower and gain |
| Contrast Set | 0 | 0 | 0 | 1 | 1 | 1 | 1 | 0 | 0 | 0 | \$78 set contrast C3, C2, C1 |
| Display ON/OFF | 0 | 0 | 0 | 0 | 0 | 0 | 1 | 1 | 1 | 1 | \$0F display on, cursor on, cursor blink |
| Clear Display | 0 | 0 | 0 | 0 | 0 | 0 | 0 | 0 | 0 | 1 | \$01 delete display, cursor at home |
| Entry Mode Set | 0 | 0 | 0 | 0 | 0 | 0 | 0 | 1 | 1 | 0 | \$06 cursor auto-increment |

Initialisation for 3.3V

| Example of initialisation: 8 bit / 5V | | | | | | | | | | | |
|---------------------------------------|----|-----|-----|-----|-----|-----|-----|-----|-----|-----|--|
| EA DOGM162 | | | | | | | | | | | |
| Command | RS | R/W | DB7 | DB6 | DB5 | DB4 | DB3 | DB2 | DB1 | DB0 | Hex Note |
| Function Set | 0 | 0 | 0 | 0 | 1 | 1 | 1 | 0 | 0 | 1 | \$39 8 bit data length, 2 lines, instruction table 1 |
| Bias Set | 0 | 0 | 0 | 0 | 0 | 1 | 1 | 1 | 0 | 0 | \$1C BS: 1/4, 2 line LCD |
| Power Control | 0 | 0 | 0 | 1 | 0 | 1 | 0 | 0 | 1 | 0 | \$52 booster off, contrast C5, set C4 |
| Follower Control | 0 | 0 | 0 | 1 | 1 | 0 | 1 | 0 | 0 | 1 | \$69 set voltage follower and gain |
| Contrast Set | 0 | 0 | 0 | 1 | 1 | 1 | 0 | 1 | 0 | 0 | \$74 set contrast C3, C2, C1 |
| Display ON/OFF | 0 | 0 | 0 | 0 | 0 | 0 | 1 | 1 | 1 | 1 | \$0F display on, cursor on, cursor blink |
| Clear Display | 0 | 0 | 0 | 0 | 0 | 0 | 0 | 0 | 0 | 1 | \$01 delete display, cursor at home |
| Entry Mode Set | 0 | 0 | 0 | 0 | 0 | 0 | 0 | 1 | 1 | 0 | \$06 cursor auto-increment |

Initialisation for 5V

EA DOGM163

| Example of initialisation: 8 bit / 3.3V | | | | | | | | | | | |
|---|----|-----|-----|-----|-----|-----|-----|-----|-----|-----|--|
| EA DOGM163 | | | | | | | | | | | |
| Befehl | RS | R/W | DB7 | DB6 | DB5 | DB4 | DB3 | DB2 | DB1 | DB0 | Hex Bemerkung |
| Function Set | 0 | 0 | 0 | 0 | 1 | 1 | 1 | 0 | 0 | 1 | \$39 8 bit data length, 2 lines, instruction table 1 |
| Bias Set | 0 | 0 | 0 | 0 | 0 | 1 | 0 | 1 | 0 | 1 | \$15 BS: 1/5, 3 line LCD |
| Power Control | 0 | 0 | 0 | 1 | 0 | 1 | 0 | 1 | 0 | 1 | \$55 booster on, contrast C5, set C4 |
| Follower Control | 0 | 0 | 0 | 1 | 1 | 0 | 1 | 1 | 1 | 0 | \$6E set voltage follower and gain |
| Contrast Set | 0 | 0 | 0 | 1 | 1 | 1 | 0 | 0 | 1 | 0 | \$72 set contrast C3, C2, C1 |
| Display ON/OFF | 0 | 0 | 0 | 0 | 0 | 0 | 1 | 1 | 1 | 1 | \$0F display on, cursor on, cursor blink |
| Clear Display | 0 | 0 | 0 | 0 | 0 | 0 | 0 | 0 | 0 | 1 | \$01 delete display, cursor at home |
| Entry Mode Set | 0 | 0 | 0 | 0 | 0 | 0 | 0 | 1 | 1 | 0 | \$06 cursor auto-increment |

Initialisation for 3.3V

| Example of initialisation: 8 bit / 5V | | | | | | | | | | | |
|---------------------------------------|----|-----|-----|-----|-----|-----|-----|-----|-----|-----|--|
| EA DOGM163 | | | | | | | | | | | |
| Command | RS | R/W | DB7 | DB6 | DB5 | DB4 | DB3 | DB2 | DB1 | DB0 | Hex Note |
| Function Set | 0 | 0 | 0 | 0 | 1 | 1 | 1 | 0 | 0 | 1 | \$39 8 bit data length, 2 lines, instruction table 1 |
| Bias Set | 0 | 0 | 0 | 0 | 0 | 1 | 1 | 1 | 0 | 1 | \$1D BS: 1/4, 3 line LCD |
| Power Control | 0 | 0 | 0 | 1 | 0 | 1 | 0 | 0 | 0 | 0 | \$50 booster off, contrast C5, set C4 |
| Follower Control | 0 | 0 | 0 | 1 | 1 | 0 | 1 | 1 | 0 | 0 | \$6C set voltage follower and gain |
| Contrast Set | 0 | 0 | 0 | 1 | 1 | 1 | 1 | 1 | 0 | 0 | \$7C set contrast C3, C2, C1 |
| Display ON/OFF | 0 | 0 | 0 | 0 | 0 | 0 | 1 | 1 | 1 | 1 | \$0F display on, cursor on, cursor blink |
| Clear Display | 0 | 0 | 0 | 0 | 0 | 0 | 0 | 0 | 0 | 1 | \$01 delete display, cursor at home |
| Entry Mode Set | 0 | 0 | 0 | 0 | 0 | 0 | 0 | 1 | 1 | 0 | \$06 cursor auto-increment |

Initialisation for 5V

EA DOG-M

DIMENSIONS

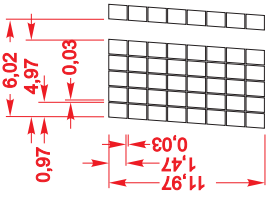
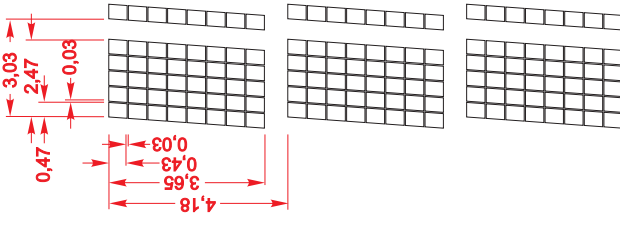
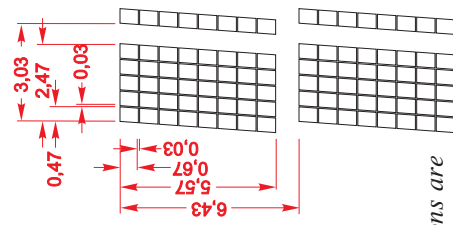
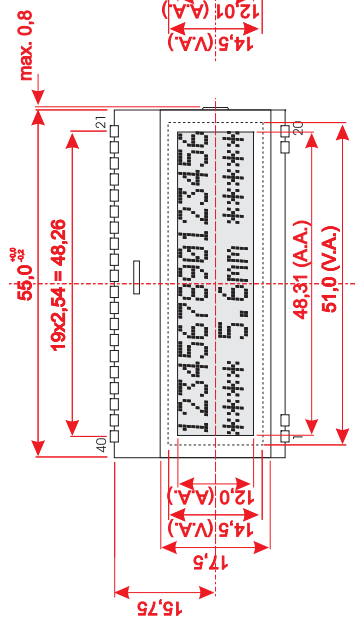
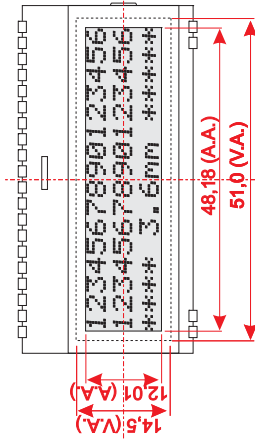
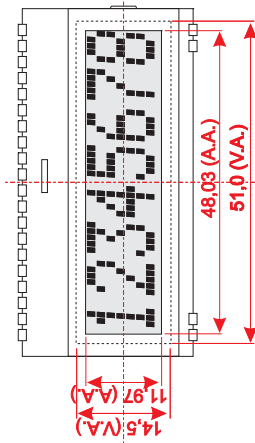
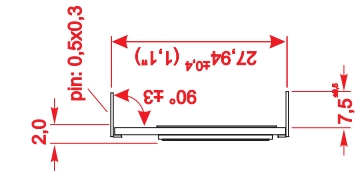

alle dimensions are in mm

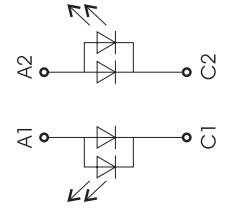
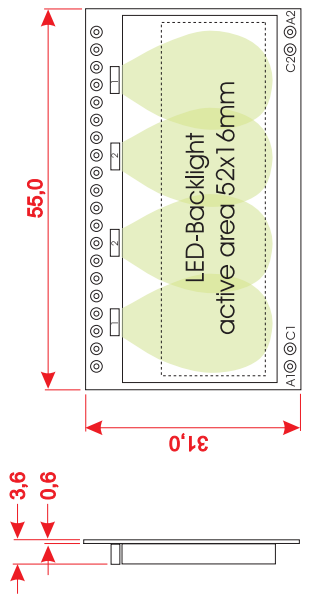

| Pin | Symbol | Level | Function |
|-----|--------|-------|----------------------------------|
| 1 | NC | | (A1+; LED backlight) |
| 2 | NC | | (C1-; LED backlight) |
| 3 | FSB | H/L | |
| 4 | VOUT | - | Voltage Booster Output |
| 5 | VIN | - | Voltage Booster Input |
| 6 | VDD | H | Power Supply +3.3..5V |
| 7 | VSS | L | Power Supply 0V (GND) |
| 8 | D7 | H/L | Display Data (MSB) |
| 9 | D6 | H/L | Display Data |
| 10 | D5 | H/L | Display Data |
| 11 | D4 | H/L | Display Data |
| 12 | D3 | H/L | Display Data |
| 13 | D2 | H/L | Display Data |
| 14 | D1 | H/L | Display Data |
| 15 | D0 | H/L | Display Data (LSB) |
| 16 | E | H | Enable (falling edge) |
| 17 | RW | H/L | L= Write, H=Read |
| 18 | CSB | L | Chip Select |
| 19 | RS | H/L | L= Command, H= Data |
| 20 | NC | | (C2+; LED backlight) |
| 21 | CAPIN | - | Voltage Booster + (0.1..1uF) |
| 22 | CAPIP | - | Voltage Booster - (0.1..1uF) |
| 23 | FSB | H/L | L= Serial Mode, H= Parallel Mode |
| 24 | VOUT | - | Voltage Booster Output |
| 25 | VIN | - | Voltage Booster Input |
| 26 | VDD | H | Power Supply +3.3..5V |
| 27 | VSS | L | Power Supply 0V (GND) |
| 28 | D7 | H/L | Display Data (MSB) |
| 29 | D6 | H/L | Display Data |
| 30 | D5 | H/L | Display Data |
| 31 | D4 | H/L | Display Data |
| 32 | D3 | H/L | Display Data |
| 33 | D2 | H/L | Display Data |
| 34 | D1 | H/L | Display Data |
| 35 | D0 | H/L | Display Data (LSB) |
| 36 | E | H | Enable (falling edge) |
| 37 | RW | H/L | L= Write, H=Read |
| 38 | CSB | L | Chip Select |
| 39 | RS | H/L | L= Command, H= Data |
| 40 | RESET | L | Reset |

Note: The 4 LED pins A1, C1, A2 and C2 must be soldered from the top to ensure a clean contact.